

# Can Seaming & Manufacturing Machine

## MODEL 8M

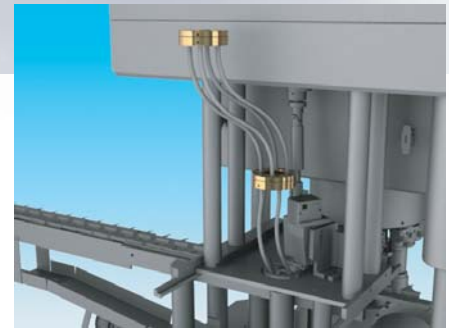

Rated Speed up to  
**1000 CPM**



- ▶ *Stainless Steel Frame Parts And Components*
- ▶ *Base Mounted Enclosure Includes Electrical Panel & Oil Filtration, Easy Mount Table For Filler*
- ▶ *Lifting Eyebolts*
- ▶ *Sloped Stainless Steel Base*
- ▶ *Quick Change Tooling (Option)*
- ▶ *PSAngelus Reliability, Service And Technical Support*

### Standard Features



*Automatic Oil Lubrication*



*Driven Lower Lifters*



*Tool Kit & Instruction Manual*



*Touchscreen Control Panel*



*Ceramic Seaming Roll Bearings*



*Filler Connecting Parts*



*Stainless Steel Casting*



*Sealed TN Coated Chromium Cobalt Seaming Rolls*



*TN Coated Chromium Cobalt Seaming Chucks*

### Optional Features



*Can Manufacturing*



*Automatic Washdown & Sterilization*



*Motor Driven Machine Height*



*Gassing Control*



*Filler Belt Drive*



*Steam Vacuum*



*Programmable Controller*

**Technical Specification**

	8M	8M
No. of Seaming Stations	8	8
Output Speed Range (CPM)	1000	1000
Min./Max. Can Diameter	200-300	50.8mm-76.2mm
Min./Max. Can Height (Atmos)	110-800	41.3mm-203.2mm
Min./Max. Can Height (Atmos) w/Raised Feed Line Package	100-800	25.4mm-203.2mm
Min./Max. Can Height (UCG & SV)	113-800	46.0mm-203.2mm
Min./Max. Can Height (UCG & SV) w/Raised Feed Line Package	103-800	30.2mm-203.2mm
Transfer Chain Pitch Can Centers	3.562	90.5mm
Mechanical Filler Drive	1 Rev/Can	Direction Reversible
Horsepower/Electrical	30HP	22 Kw
Electrical Controls	24 Volt DC	24 Volt DC
Dry Air @ Base & Upper Turret Housing	2psi @ gauge	0.2 bars @ gauge
CO <sup>2</sup> /Nitrogen Gas Supply Pressure	100psi @ 70°F	6.9 bars @ 21°C
CIP Cleaning – Hot Water	160°F @ 70psi	71°C @ 4.8 bars
CIP Cleaning – Steam	330°F @ 80psi	165°C @ 5.5 bars
Net Weight (Approx.)	TBD	TBD
Gross Weight Domestic (Approx.)	TBD	TBD
Gross Weight Export (Approx.)	TBD	TBD

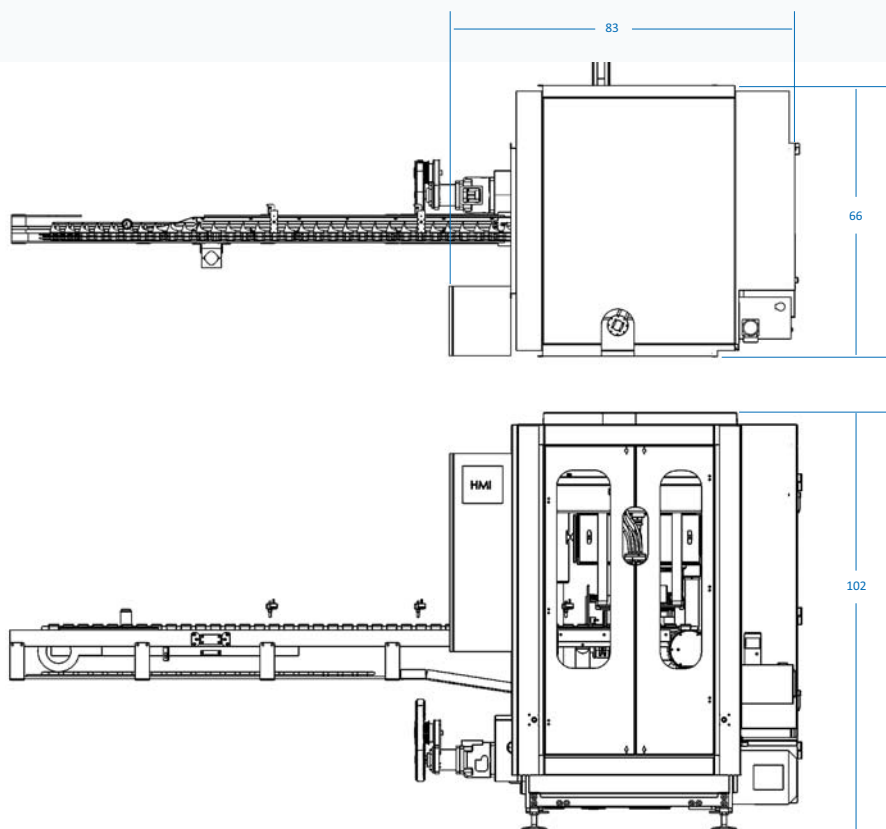

**Pneumatic Scale Angelus - Los Angeles**

4900 Pacific Blvd, Los Angeles, CA 90058 Tel: 323-583-2171 Fax: 323-587-5607

**Pneumatic Scale Angelus - Arkon**

10 Ascot Parkway, Cuyahoga Falls, OH 44223 Tel: 330-923-0491 Fax: 330-923-5570

www.psangelus.com

